

LUMINARIO LED REFLECTOR STD CON SENSOR

 Exterior

*La mejor opción
para exterior*



LUMINARIO LED REFLECTOR STD CON SENSOR

La familia de LED Boomer Lighting^{MR}, con sensor de movimiento y pantalla frosted.

30 W

LUZ DE DÍA 6 500 K ●

APLICACIONES



- Fraccionamientos residenciales
- Patios y terrazas
- Casetas de vigilancia
- Estacionamientos abierto
- Iluminación de:
 - Pasillos
 - Patios
 - Casetas
 - Jardines

BENEFICIOS

- Sensor de movimiento
- Tornillos de acero inoxidable
- Válvula de liberación para calor y humedad
- Protección de picos 6kV
- Pantalla de vidrio frosted templado que permite una mayor difusión de la luz



LUMINARIO LED REFLECTOR STD CON SENSOR

<ul style="list-style-type: none">  Negro  2 700 lm  25 000 h  120 °  Uso Exterior  IP - 65 	<p>Material Aluminio Pantalla Vidrio</p> <p>Factor de potencia >0.9</p> <p>Distancia de detección 6 - 10 m <small>"SENS" (Ajustable)</small></p> <p>Tiempo de espera 10 seg - 8 min <small>"TIME" (Ajustable)</small></p> <p>Iluminancia 2 - 2 000 lux <small>"LUX" (Ajustable)</small></p> <p>Velocidad detección 0.6 - 1.5 m/s</p>	<ul style="list-style-type: none"> • Ahorro del 90% • Resistente a chorros de agua y polvo • No atenuable • Bajo costo de mantenimiento.
---	---	--

Información Técnica

Modelo	Potencia	Voltaje	Frecuencia	Corriente	Dimensiones (mm)
BLFS-2101-03065	30 W	100 V~ - 240 V~	50 Hz / 60 Hz	0.30 A - 0.12 A	205*160*55

*Referir su consulta al marcado o etiquetado del luminario.

Dimensiones

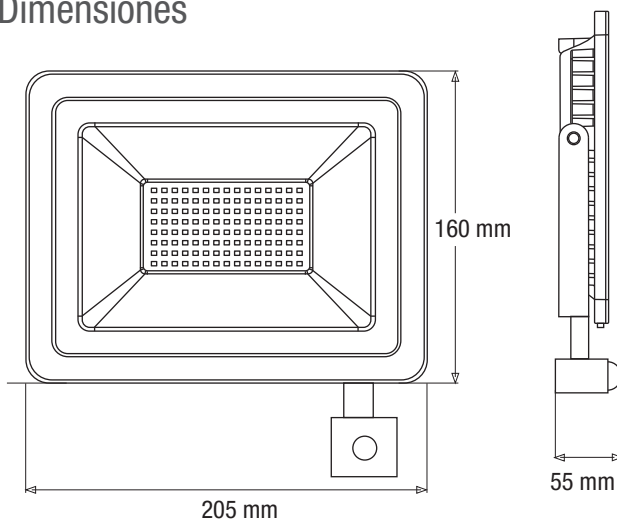

LED NOM

Importador: CDC WIRE S. de R.L. de C.V.
Altos Hornos 1279, Col. Parque Industrial,
El Álamo, C.P. 44490, Guadalajara, Jalisco
RFC: CWI 041019 RI7
Hecho en China.

